



SO₂ measurement on flue gas desulfurization systems

Instruction manual



1.1. Ensure safety

 CAUTION
Danger of burning on hot surfaces!
> Allow the probe shaft to cool down after a measurement before touching it or placing it in the transport packaging.

SO₂low sensor with special SO₂low gas sampling probe and SO₂low sensor with heated gas sampling system

- > Temperatures given on probes/sensors relate only to the measuring range of the sensors. Do not expose handles and feed lines to any temperatures in excess of 70 °C unless they are expressly permitted for higher temperatures.
- > Carry out only the maintenance and repair work on this instrument that is described in the documentation. Follow the prescribed steps exactly. Use only original spare parts from Testo.
- > Do not store the product together with solvents. Do not use any desiccants.
- > Do not perform contact measurements on non-insulated, live parts.
- > Only operate the product properly, for its intended purpose and within the parameters specified in the technical data. Do not use any force.

SO₂low sensor with heated gas sampling system

- > When connecting the probe ensure correct line voltage as specified on the type plate.
- > Pull out the mains plug before opening the probe housing.
- > After assembling the probe check all screw joints for leak tightness.

2 Specifications

2.1. Use

For the SO₂low measurement on flue gas desulfurization systems two sets are available:

SO₂low sensor with special SO₂low gas sampling probe

(0563 1251) consisting of:

- SO₂low sensor:
0...200 ppm, resolution 0.1 ppm
- special gas sampling probe for SO₂low measurement:
Length of probe shaft 735 mm incl. cone, thermocouple NiCr-Ni, T_{max}. Probe shaft 220 °C, hose length 2.35 m, diameter of probe shaft 8 mm

SO₂low sensor with heated gas sampling system (0563 2251)

consisting of:

- SO₂low sensor:
0...200 ppm, resolution 0.1 ppm
- Heated gas sampling tube:
Electric power supply 230 V/50 Hz, material stainless steel 1.4571, heating: >+180 °C, electrical connection to heated handle; thermocouple NiCr-Ni, length 1.2 m
- Heated gas sampling hose
Hose length 4 m.

Both the SO₂low sensor with special SO₂low gas sampling probe and the SO₂low sensor with heated gas sampling system have been specially developed for SO₂low measurements in flue gas desulfurization systems. A measurement requires the use of a measuring system consisting of the flue gas analyser testo 350 fitted with a SO₂low sensor and a Peltier gas preparation with peristaltic pump for automatic condensate drainage, and a special SO₂low gas sampling probe or a heated gas sampling system.

2.2. Technical data

2.2.1. SO₂low sensor

Feature	Values
Measurement range	0...200 ppm
Accuracy	<p>± 2 ppm (0...39.9 ppm) ± 5 % of mv. (40.0...200 ppm)</p> <p>In order to maintain the accuracy during the measurement, the ambient temperature should not fluctuate more than ±5 K and the instrument temperature of the testo 350 not more than >±3 K).</p> <p>For achieving the highest possible accuracy we additionally recommend to apply calibration gas (ideally a test gas concentration in the range of the measured or expected flue gas concentration is used for calibration) at the probe tip of the SO₂low gas sampling probe without pressure. This way the complete system (SO₂low gas sampling probe and flue gas analyser) is calibrated or re-adjusted.</p>
Response time (t ₉₀)	30 s
Resolution	0.1 ppm

2.2.2. Special SO₂low gas sampling probe

Feature	Values
Probe shaft length	735 mm
Probe shaft diameter	8 mm
Application range temperature	max. +220 °C
Hose length	2.35 m (optional lengths up to max. 10 m)

Thermocouple

Feature	Values
Thermocouple	1 mm insulated
Sensor type	Type K (NiCr-Ni), Tol. Class 1
Measurement range of thermocouple	-60...+1000 °C

2.2.3. Heated gas sampling system

Feature	Values
Ambient temperature	-20 °C...+50 °C

Heated probe shaft

Feature	Values
Gas temperature	Heated probe shafts max. +600 °C
Power supply	0600 7630: 230 V/50 Hz
Temperature of gas path	>180 °C
Dimensions	ø25 mm, Length 1 m
Weight	2400 g
Power consumption	650 W

Heated sampling hose

Feature	Values
Hose length	4 m
Hose caliber	34 mm
Material	corrugated hose
Heating temperature area	>120 °C

Thermocouple

Feature	Values
Thermocouple	1 mm insulated
Sensor type	Type K (NiCr-Ni), Tol. Class 1
Measurement range of thermocouple	Tmax: 1.200°C

3 Product description

3.1. SO₂low sensor with special SO₂low gas sampling probe

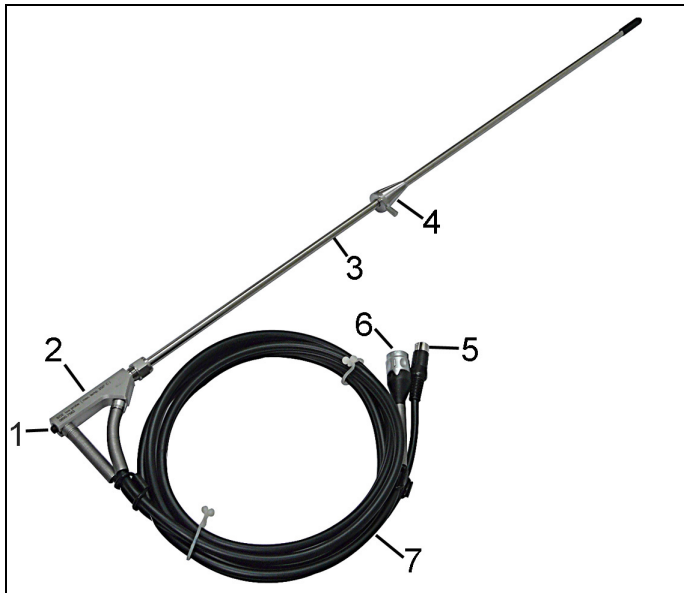

- 1 Thermocouple
- 2 Probe handle
- 3 Detachable probe shaft
- 4 Cone
- 5 Connecting plug for thermocouple
- 6 Connecting plug for flue gas probe
- 7 Hose

3.2. SO₂low sensor with heated gas sampling system

3.2.1. Heated probe shaft



The heated sampling tube is operated with 230 V, 50 Hz line voltage. Power consumption: 650 Watt.

The sampling tube consists of a coaxial tube (2) with a laterally attached junction box (3).

The coaxial tube has an outer diameter of 25 mm and its end is fitted with a G1/4" threaded socket (4) for connecting the pre-filter or for extending with an unheated sampling tube.

A helical tubular heater to heat up the sampling tube is arranged inside the coaxial tube (2). A thermostat regulates the temperature to 180 °C. The controller is installed inside the junction box (3). The power supply cable with plug connector connects the system to the electric power supply. The sampling tube is heated up together with the handle within a heating up period of 20 min.

3.2.2. Thermocouple (NiCr-Ni)

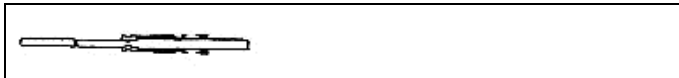

For measuring the flue gas temperature there is the possibility to insert a NiCr-Ni thermocouple through the handle and the sampling tube.

4 Using the product

4.1. General notes on SO₂low measurement

SO₂low measurement in case of presence of NH₃ in flue gas (only in connection with SCR catalysts)

i The start-up of a system with flue gas desulfurization (incl. SCR catalyst (selective catalytic reduction)) can take up to 2 hours. Reason: the temperature of the components in contact with the flue gas is decisive for the correct timing of the NH₃ injection. No SO₂low measurement must be executed during this time.

i Shutting down a flue gas cleaning system incl. SCR catalyst takes about 30 min. No SO₂low measurement must be executed during this phase.

i In case of NH₃ being present in the flue gas with a concentration of up to max. 100 ppm NH₃, a SO₂low measurement can only be performed over max. 15 min. In case of a longer exposure the SO₂low probe may be damaged or one may obtain incorrect measuring results.

i In flue gas cleaning facilities in which high NH₃ concentrations may most likely occur, a re-calibration of the SO₂low sensor or of the entire system (see technical data) should be carried out. If, in case of a re-calibration, the SO₂ end value is not stable after a period of 3 minutes, this points to sensor damage and thus to an incorrect measuring result.

Performing measurement/adjustment

Prerequisite for compliance with the meas. uncertainty:

- a stable ambient temperature during the measurement (fluctuation $< \pm 5$ °C)
- a temperature stable instrument (change in instrument temperature during measurement $< \pm 3$ °C).

For a highly accurate SO₂ measurement the complete system should be adjusted with test gas before the measurement is performed.

- > Use a suitable piece of hose to connect the test connection to the SO₂low probe:

Hose data:

Feature	Values
Length	100 mm
Materials	Silicone
Wall thickness	2 mm
Inner diameter	6.5...7.5 mm

- > Push the silicon hose over the tip of the SO₂low probe so that the openings are completely covered.
- > Perform calibration (see operating instructions testo 350, re-calibration / adjustment).

i The measuring accuracy of the SO₂low sensor can be increased by adjusting the cross sensitivity against CO and NO₂. This requires that the testo 350 is equipped with the CO and NO₂ sensor. The cross sensitivity adjustment can be executed via the easyEmission software.

- > With CO concentrations >100 ppm perform a cross adjustment of the SO₂low sensor against CO.
- > With N₂O concentrations >10 ppm perform a cross adjustment of the SO₂low sensor against NO₂.

i With high CO values >500 ppm no COlow sensor should be used.

4.2. SO₂low sensor with special SO₂low gas sampling probe

Checking the thermocouple

- > Make sure that the thermocouple of the flue gas probe does not touch the probe basket. Bend the thermocouple back if necessary.

Aligning the flue gas probe

- > Turn the probe to align the thermocouple so that it is freely exposed to the flue gas flow.
- > Align the flue gas probe in the flue gas duct so that the tip is in the hot spot (area of the highest flue gas temperature).

i The set is delivered fully assembled

5 Maintaining the product

5.1. Changing the thermocouple

5.1.1. SO₂low sensor with special SO₂low gas sampling probe

i Before replacing the thermocouple disconnect the SO₂low probe from the meas. box.

i Remove the thermocouple only if defective.

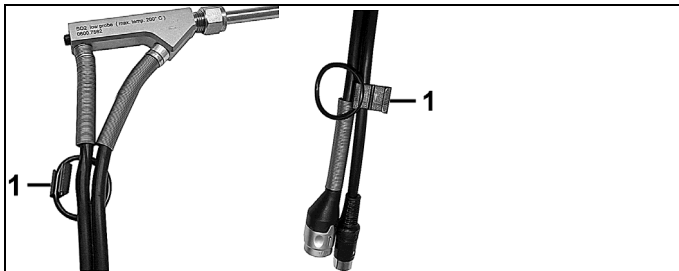

1. Loosen the hose clamps (1) on the hose.

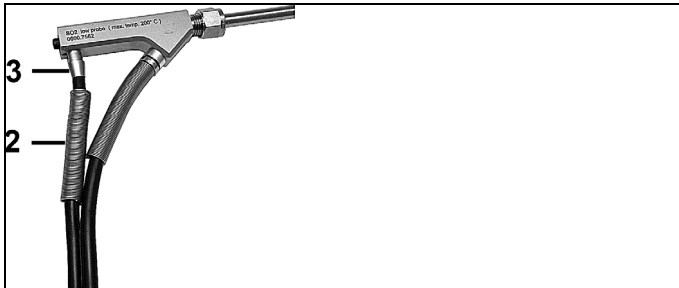

2. Pull the bend protection spring (2) at the rear hose branch (3) off the hose connection by turning it anti-clockwise.

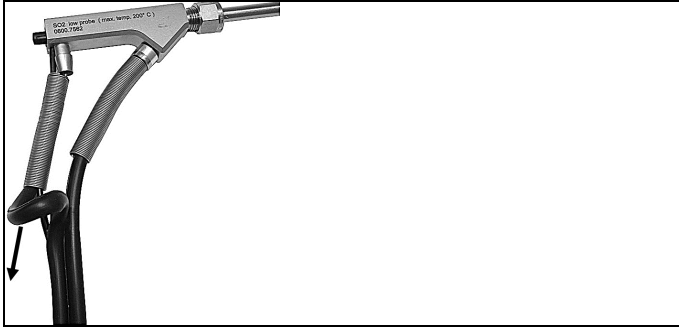

3. Pull the hose out of the hose connection and the bend protection spring (2).

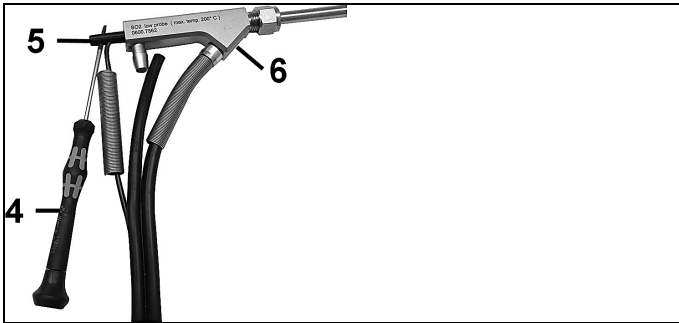

4. Use a screwdriver (4) to pull the thermocouple out of the plastic bracket (5) on the probe handle (6).

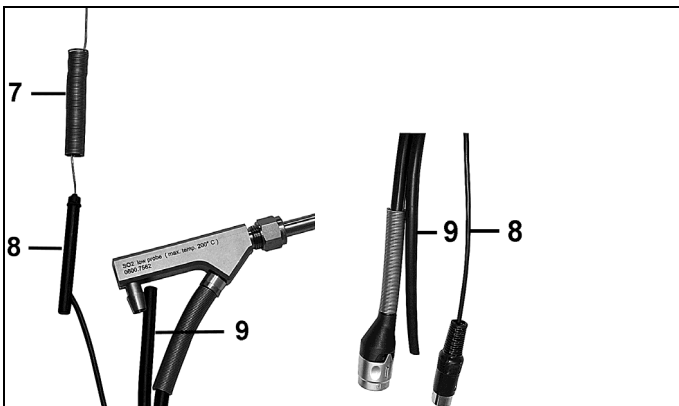

- 5 Pull the bend protection spring (7) over the thermocouple (8) and remove the cable of the thermocouple (8) from the split hose (9).
6. Slide the bend protection spring (7) over the new thermocouple (8) (only so far, that the cable of the thermocouple can be completely inserted into the split hose (9)).

i Before assembling the thermocouple (8) cover the O-ring with lubricant, e.g. grease, to prevent the O-ring from getting damaged.

When inserting the new thermocouple (8) into the handle do not press against the cable of the thermocouple, but against the plastic bracket.

7. Carefully thread the thermocouple (8) through the probe handle into the probe shaft, do not buckle the thermocouple (8) while doing this.
8. Insert the cable of the new thermocouple into the split hose (9) and guide it through the bend protection spring (7).
9. Push thermocouple (8) and hose (9) into the hose connection.
10. Push the bend protection spring (7) over the hose connection by pressing and simultaneously turning it clockwise.
11. Fasten the hose clamps (1) on the hose.

Tightness test

(only available via **Meas. Box** tab)

The leak test requires a plastic cap (0193 0039, comes with the SO2low probe).

Calling up the function:

>  → **Instrument diagnose** → **[OK]** → **Gas path check** → **[OK]**.

or

> **[i]** → **Gas path check** → **[OK]**.

1. Place the plastic cap on the tip of the SO2low probe so that the openings are completely covered.
 - The pump flow is displayed.
 - Volumetric flow rate less than or equal to 0.04 l/min:
The gas paths are leak tight (traffic light in display lights green).

- Volumetric flow rate higher than 0.04 l/min:
The gas paths are leaking (traffic light in display lights red).
SO2low probe and meas. box must be checked for leaks.

5.1.2. SO2low sensor with heated gas sampling system

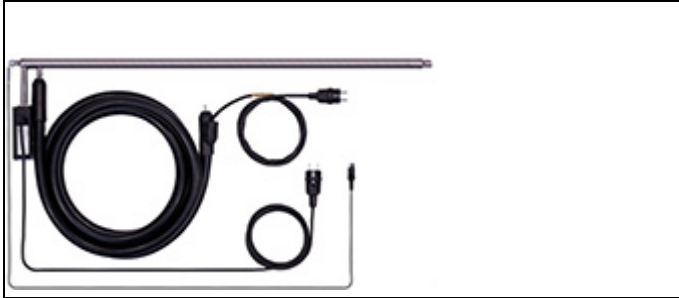

i Before replacing the thermocouple, disconnect the industrial flue gas probe from the Testo measuring instrument.

1. Undo all hose clamps on the gas sampling hose.
2. Remove bend protection springs from the thermocouple clamping screw.
3. Undo the thermocouple clamping screw using a wrench (size SW8).
4. Carefully pull out thermocouple.
5. Remove the thermocouple cable, starting at the instrument plug, from the slotted tube.

ATTENTION

Never pull on the connection cable when removing the thermocouple from the handle.

Damage due to inappropriate handling!

- > Hold thermocouple tightly in front of the ferrule and carefully pull it out of the handle.
6. Remove bend protection spring from the thermocouple.
 7. Attach bend protection spring to the new thermocouple.
 8. Insert the new thermocouple cable, starting at the instrument plug, into the slotted tube.
 9. Push the bend protection spring over the tube.

10. Carefully thread the new thermocouple up to 50 mm through the clamping screw and the probe handle into the probe shaft.
11. Screw the clamping screw by hand as far as it will go. Then tighten using a wrench (size SW8) with 1 3/4 turns.

i When refitting the same clamping screw, this is tightened with a 1/4 turn more.

12. Carefully bend thermocouple 90° between ferrule and clamping screw connection. Do not kink the thermocouple.
13. Push bend protection springs over the clamping screw.
14. Fasten hose clamps to the gas sampling hose.

i After the assembly procedure check the screw fittings for leak tightness.

6 Tips and assistance

6.1. Questions and answers

Question	Possible causes
After 3 minutes the measurement value has not reached a stable end value.	<ul style="list-style-type: none"> • Excessive exposure of sensor to NH₃-concentration. • Sensor damaged by too high NH₃-values. <p>> Replace the sensor and avoid measurements with high NH₃-values.</p>
How can I determine whether the flue gas contains high NH ₃ -values?	<p>> Check NH₃-concentration using available measuring technology, e.g. short-term tubes for measuring NH₃-concentration.</p>

If we were not able to answer your question, please contact your local dealer or Testo's Customer Service. Contact data see back of this document or website www.testo.com/service-contact.

6.2. Accessories and spare parts

6.2.1. SO₂low sensor with special SO₂low gas sampling probe

Description	Article no.
SO ₂ low sensor with special SO ₂ low gas sampling probe	0563 1251
Spare thermocouple	0430 0053
Spare SO ₂ low sensor	0393 0251

6.2.2. SO₂low sensor with heated gas sampling system

SO ₂ low sensor with heated gas sampling system	0563 2251
Spare SO ₂ low sensor	0393 0251
Heated sampling tube (230 V/50 Hz) ø0.25 mm, length 1 m, stainless steel 1.4571, heating controlled to 180 °C	0600 7820
Heated sampling hose (230 V 150 Hz) Length 4 m, including filter element and retrofit SO ₂ low sensor, temperature range +5 °C ... +50 °C	0600 3502
Thermocouple NiCr-Ni ø2.0 mm, length 1.2 m, with 4 m connecting cable	0430 0088
PTFE V-ring seal for connecting fitting heated sampling tube	0135.0515
PTFE V-ring seal for screw fitting thermocouple	0135.0516
G1/4" adapter for heated probe shafts	0400.0516

